

■DESCRIPTION

The RS-160 can call and converse with the registered master stations.
It utilizes a 2-core shielded cable.

■SPECIFICATIONS

Rated Input	1 W
Rated Impedance	625 Ω (1 W/25 V)
Internal Speaker	4 cm cone-type
Wiring	Two-core shielded cable
Transmission Range	0.5 km (546 yd)/∅0.5 mm (AWG24) 0.8 km (874 yd)/∅0.65 mm (AWG22) 1.3 km (1421 yd)/∅0.9 mm (AWG19)
Operating Temperature	-10 °C to +50 °C (Temperature range not to freeze the speaker and switch)
Finish	Panel: Stainless steel, hairline Call button: Metal
Dimensions	120 (W) × 120 (H) × 57.5 (D) mm
Weight	540 g
Accessory	Box mounting screw (No.6-32UNC × 8)4, Box mounting screw (M4 × 25)4
Applicable Box	For flush-mount: 2-gang electrical box YC-302 (option) For surface-mount: Indoor wall-mount box YC-822 (option)

■APPEARANCE

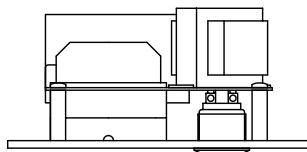

Top View

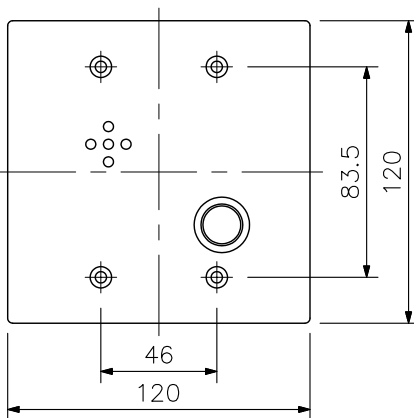

Front View

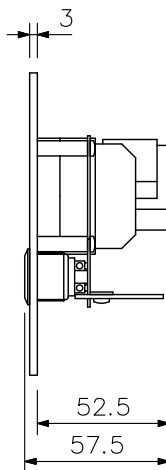

Side View

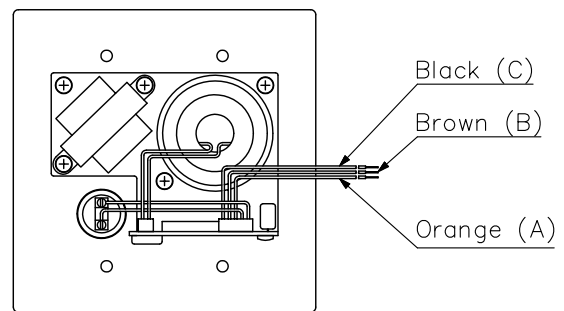

Rear View

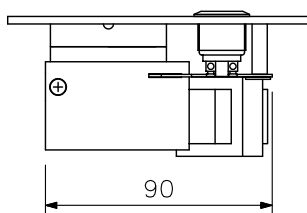

Bottom View

UNIT:mm SCALE:1/3